

3BUILT MOTORSPORTS / HELIOSURE END USER AGREEMENT

NOTICE TO USER: PLEASE READ THIS AGREEMENT CAREFULLY. BY INSTALLING AND/OR USING ALL OR ANY PORTION OF THIS PRODUCT YOU ACCEPT ALL THE TERMS AND CONDITIONS OF THIS AGREEMENT ; WARRANTY IN SECTION 3; LIABILITY IN SECTION 5. YOU AGREE THAT THIS AGREEMENT IS LIKE ANY WRITTEN NEGOTIATED AGREEMENT SIGNED BY YOU. THIS AGREEMENT IS ENFORCEABLE AGAINST YOU AND ANY LEGAL ENTITY THAT OBTAINED THE PRODUCT AND ON WHOSE BEHALF IT IS USED.

IF YOU DO NOT AGREE TO THE TERMS OF THIS AGREEMENT OR ARE UNDER 18 YEARS OLD, DO NOT INSTALL OR USE THIS PRODUCT. RETURN UNUSED PRODUCT WITHIN TEN (10) DAYS OF PURCHASE FOR A FULL REFUND OF PURCHASE PRICE. VISIT [HTTP://WWW.HELIOSURE.COM](http://www.heliosure.com) OR E-MAIL SALES@HELIOSURE.COM FOR REFUND INFORMATION.

1. DEFINITIONS

- a. "3Built Motorsports", a California Sole Proprietorship, 7622 Farndale Ave., North Hollywood, Ca. 91605.
- b. "Heliosure" is 3Built Motorsports
- c. "Product" means any item sold 3Built Motorsports.
- d. "Documentation" means the Installation and Use Instructions or other paperwork sent with the Product.

2. FUNCTIONALITY AND RANGE. Some items are radio frequency controlled devices. They are susceptible to radio frequency interference. The control signal is encoded to reduce the possibility of interference, but it cannot be eliminated. The interference may cause the Product not to function as stated or desired. This may include non-operation, decreased range, and accidental activation of the Product.

3. LIMITED WARRANTY. 3Built Motorsports warrants to the individual or entity that first purchases the Product pursuant to the terms of this agreement that the Product will perform substantially in accordance with the Documentation for the sixty (60) day period following receipt of the Product when used as directed in the Documentation. Non-substantial variation of performance from the Documentation does not establish a warranty right. THIS LIMITED WARRANTY DOES NOT APPLY TO IMPROPERLY INSTALLED, ALTERED OR ABUSED PRODUCT. All warranty claims must be made, along with proof of purchase, within such sixty (60) day period. If the Product does not perform substantially in accordance with the Documentation, the entire liability of 3Built Motorsports and its affiliates and your exclusive remedy will be limited to either, at 3Built Motorsports' option, replacement of the Product or refund of the purchase price paid for the Product. THE LIMITED WARRANTY SET FORTH IN THIS SECTION GIVES YOU SPECIFIC LEGAL RIGHTS. YOU MAY HAVE ADDITIONAL RIGHTS WHICH VARY FROM JURISDICTION TO JURISDICTION.

4. DISCLAIMER. THE FOREGOING LIMITED WARRANTY IS THE ONLY WARRANTY MADE BY 3BUILT MOTORSPORTS AND ITS AFFILIATES AND STATES THE SOLE AND EXCLUSIVE REMEDIES FOR 3BUILT MOTORSPORTS, ITS AFFILIATES OR SUPPLIERS' BREACH OF WARRANTY. EXCEPT FOR THE FOREGOING LIMITED WARRANTY AND ANY WARRANTY, CONDITION, REPRESENTATION OR TERM TO THE EXTENT THE SAME CANNOT OR MAY NOT BE EXCLUDED OR LIMITED BY LAW APPLICABLE TO YOU IN YOUR JURISDICTION, 3BUILT MOTORSPORTS AND ITS AFFILIATES AND SUPPLIERS PROVIDE THE PRODUCT *AS-IS* AND *WITH ALL FAULTS* AND EXPRESSLY DISCLAIM ALL OTHER WARRANTIES, CONDITION, REPRESENTATIONS OR TERMS, EXPRESS OR IMPLIED, WHETHER BY STATUTE, COMMON LAW, CUSTOM, USAGE OR OTHERWISE AS TO ANY MATTER, INCLUDING BUT NOT LIMITED TO PERFORMANCE, SECURITY, NON-INFRINGEMENT OF THIRD PARTY RIGHTS, INTEGRATION, MERCHANTABILITY, QUIET ENJOYMENT, SATISFACTORY QUALITY OR FITNESS FOR ANY PARTICULAR PURPOSE. The provisions of Sections 4 and Section 5 will survive the termination of this agreement, howsoever caused, but this will not imply or create any continued right to use the Product after termination of this Agreement.

5. **LIMITATION OF LIABILITY.** EXCEPT FOR THE EXCLUSIVE REMEDY SET FORTH ABOVE AND AS OTHERWISE PROVIDED IN SECTION 3, IN NO EVENT WILL 3BUILT MOTORSPORTS OR ITS AFFILIATES OR SUPPLIERS BE LIABLE TO YOU FOR ANY LOSS, DAMAGES, CLAIMS OR COSTS WHATSOEVER INCLUDING ANY CONSEQUENTIAL, INDIRECT OR INCIDENTAL DAMAGES, ANY LOST PROFITS OR LOST SAVINGS, ANY DAMAGES RESULTING FROM BUSINESS INTERRUPTION, PERSONAL INJURY OR FAILURE TO MEET ANY DUTY OF CARE, OR CLAIMS BY A THIRD PARTY, EVEN IF A 3BUILT REPRESENTATIVE HAS BEEN ADVISED OF THE POSSIBILITY OF SUCH LOSS, DAMAGES, CLAIMS OR COSTS. THE FOREGOING LIMITATIONS AND EXCLUSIONS APPLY TO THE EXTENT PERMITTED BY APPLICABLE LAW IN YOUR JURISDICTION. 3BUILT MOTORSPORTS' AGGREGATE LIABILITY AND THAT OF ITS AFFILIATES AND SUPPLIERS UNDER OR IN CONNECTION WITH THIS AGREEMENT WILL BE LIMITED TO THE AMOUNT PAID FOR THE PRODUCT, IF ANY. THIS LIMITATION WILL APPLY EVEN IN THE EVENT OF A FUNDAMENTAL OR MATERIAL BREACH OR A BREACH OF THE FUNDAMENTAL OR MATERIAL TERMS OF THIS AGREEMENT.
6. **INDEMNITY.** You agree to hold 3Built Motorsports harmless from any and all liabilities, losses, actions, damages, or claims (including all reasonable expenses, costs, and attorneys fees) arising out of or relating to any use of, or reliance on, the Product, including, without limitation reliance on a) batteries, b) range, c) installation, d) performance, and e) failure to exercise reasonable judgment. Nothing contained in this agreement limits 3Built Motorsports' liability to you in the event of death or personal injury resulting from 3Built Motorsports' negligence or for the tort of deceit (fraud). 3Built Motorsports is acting on behalf of its affiliates and suppliers for the purpose of disclaiming, excluding and limiting obligations, warranties and liability, but in no other respects and for no other purpose.
7. **GOVERNING LAW.** This agreement will be governed by and construed in accordance with the substantive laws in force in the State of California, if the Product is purchased when you are in the United States, Canada, or Mexico.
8. **GENERAL PROVISIONS.** If any part of this agreement is found void and unenforceable, it will not affect the validity of the balance of this agreement, which will remain valid and enforceable according to its terms. This agreement will not prejudice the statutory rights of any party dealing as a consumer. This agreement may only be modified by a writing signed by an authorized member of 3Built Motorsports. This is the entire agreement between 3Built Motorsports and you relating to the Product and it supercedes any prior representations, discussions, undertakings, communications, or advertising relating to the Product.



Remote Ignition Interrupter

HE-RII

INSTALLATION INSTRUCTIONS

WARNING

BY INSTALLING OR USING THIS PRODUCT YOU AGREE TO OUR “END USER AGREEMENT”. IT IS INCLUDED WITH THESE INSTRUCTIONS AND AVAILABLE ON-LINE AT <https://heliosure.com/support>

Use of this product could result in injuries and/or property damage due to the sudden loss of engine power. Vehicles may lose stability when engine power is disabled. Control of the vehicle will also be limited after engine is disabled. This product will not stop a vehicle. It will not apply the brakes or any other mechanism to reduce speed. It is designed to disable the engine by shutting off the ignition system. It functions similarly to the vehicle's stock ignition ON/OFF switch. Use extreme caution as to when and where the vehicle is before disabling the engine. Proper judgment must be used when disabling engine power. **Performance and range is not guaranteed.** Radio frequency interference may be common in some areas and can affect this product's range and performance. Use of motor vehicles is an inherently dangerous activity. Wear proper protective gear when operating the vehicle. If any doubt of potential injury, do not use. Once installed, to understand how this product functions, test the device by disabling the vehicle's engine, first at idle and then at low speed. This product's installation and use is at your own risk. This product is intended to be installed and used by adults only.

This device complies with part 15 of the FCC Rules. Operation is subject to the following two conditions: (1) This device may not cause harmful interference, and (2) this device must accept any interference received, including interference that may cause undesired operation.

INCLUDED PARTS

(1) Receiver (1) Transmitter (1) USB Cable (1) USB Charger

GETTING STARTED

- 1) **All radio transmissions are susceptible to interference from many sources.** Interference can cause reduced range or complete loss of communication between the *Transmitter* and *Receiver*. Resistor spark plugs and suppression type spark plug wires may reduce radio interference.
- 2) **Do not connect any wire to the high voltage spark plug wire.**
- 3) Installation of this device requires electrical and electronics knowledge.
- 4) You should have a wiring diagram for your vehicle before installation. This may be available from your dealer in the Repair Manual for your vehicle.
- 5) This device is a remotely activated switch. The switch can be connected as a normally-open or normally-closed switch while the vehicle is in the RUN mode. **The internal relay is limited to switching 8 amperes, maximum.**
- 6) It is important to determine your OEM (original equipment manufacturer) RUN/STOP switch type before installation. Improper installation of this unit can damage your vehicle's electrical system and components. If unsure, please consult a professional.

DEFINITIONS

OEM - Original Equipment Manufacturer. This is any component that the vehicle originally came equipped with from the factory.

RII – Remote Ignition Interrupter

Normally-open - means that the switch is open (no connection) when the *RII* is in the RUN mode. This connection type is typically used for ground type OEM RUN/STOP switches.

Normally-closed - means that the switch is closed (connected) when the *RII* is in the RUN mode. This connection type is typically used on positive voltage type OEM Run/Stop switches.

INSTALLATION

- 1) Charge the *Transmitter* by plugging it in to a USB charger (5 volts). The cable is a USB-A to USB-mini-B. With the power switch off, you will see a small red or blue light towards the bottom of the *Transmitter* (small window) while charging. The included lithium battery is designed for hundreds of charge cycles. It can be replaced, if necessary, with another lithium-ion 18500 size battery.
Blue LED = fully charged ; Red LED = charging
- 2) Find a suitable place to mount the *Receiver*. Position it so that it will stay dry and will not be damaged in case of an accident.
- 3) Attach the Red Wire on the *Receiver* to a 12 volt DC power supply such as a car battery. We recommend that you use a fuse if connecting directly to a battery or un-fused power wire. Improperly mounted wires can become damaged and short to the frame causing damage to the vehicle, *R/I*, and/or driver. Damage may include high heat and/or fire.
- 4) Attach the Black Wire to ground.
- 5) Choose either Normally Closed or Normally Open connection type.

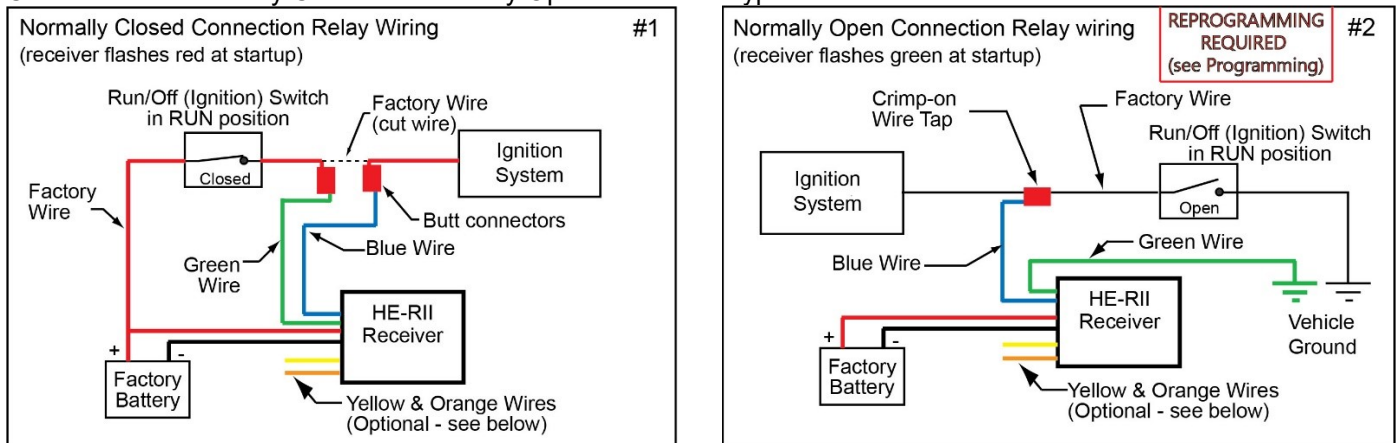

a. **Normally Closed Connection for Relay (8-amp max.) [diagram #1] (Default state)**

- Typical for MSD 6, MSD 7, and MSD Pro Mag 44

This is used typically when an ignition system needs to be powered from the battery. It is very important to cut the correct wire for proper operation. Incorrect wiring can damage the ignition module or other electrical component. Use caution and consult a professional if unsure.

Blue Wire – Identify the power wire from the OEM Run/Stop switch to the ignition module. Cut the wire and attach the *Blue Wire* to one end of the cut wire

Green Wire – Attach the *Green Wire* to the other end of the previously cut wire. It does not matter which wire is attached to which side of the cut wire.

b. **Normally Open Connection for Relay (8-amp max.) [diagram #1]**

- Typical for MSD Pro Mag 12

*****Must perform "NORMALLY-OPEN MODE" steps in PROGRAMMING section. *****

This is typically used when an ignition system must be grounded to shut off the vehicle.

Blue Wire – The wire will be attached to the vehicle's electrical system. The OEM RUN/STOP switch has two wires. One comes from the ignition module and the other goes to the vehicle's ground. Splice the *Blue Wire* between the ignition module and the OEM Run/Stop switch. Attaching the *Blue Wire* to an incorrect wire may damage the ignition module or other electrical component. Use caution and consult a professional if unsure.

Green Wire - Attach *Green Wire* to vehicle ground or negative side of battery.

- 6) Flip the power switch on the side of the *Receiver*. The green LED will illuminate.
 - a. **Green LED** = *Receiver* in RUN mode
 - b. **Red LED** = *Receiver* in OFF mode
- 7) Turn on the *Transmitter* by flipping the power switch at the top. It will communicate with the *Receiver* and display a status:
 - a. **Green LED** = *Receiver* in RUN mode
 - b. **Red LED** = *Receiver* in OFF mode
 - c. **Yellow LED** = *Transmitter* CANNOT connect to the *Receiver*.
 - i. **Either the *Receiver* is turned off** (Check on/off switch on *Receiver* or check the connection and ensure black and red wire are connected to the 12 volt battery)
 - ii. **or the *Receiver* is out of range** (Move closer and press either the run button or off button until you receive a solid Green or Red light. Once the light turns from yellow to either solid red or green you are now at the maximum range. Make a note of this distance.).
 - iii. **Blinking** - *Transmitter* is sending command to *Receiver*

- 8) Press the Red button. The Red LED on the *Receiver* and *Transmitter* will illuminate. The engine should now be disabled.
 - a. It will be impossible to restart the engine until the *Receiver* shows a Green LED or it is turned off in normally-open installations.
- 9) Press the Green button to allow the engine to run. The GREEN LED on the *Receiver* and *Transmitter* will illuminate.
- 10) Test the system again at low speed to understand how the system operates. Engine power will be disabled when the Red button is pressed within range of the vehicle. **The RES will not slow down or stop the vehicle. The RES only disables the engine.**
- 11) **The Receiver consumes a small amount of power from the battery.** (This is normal for all radio frequency receivers.) We recommend shutting the *Receiver* off with the toggle switch when not in use.
- 12) **OPTIONAL Solid State Switch (5-amp max.)** – The *Rll* has two secondary solid state switches that are not prone to typical relay high vibration issues. They can be used to activate lights or other devices.

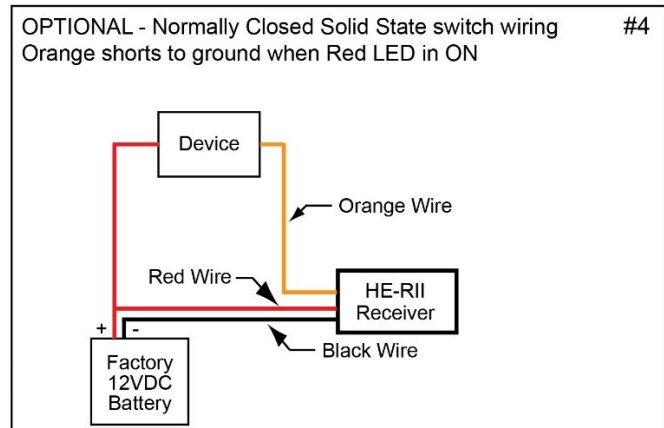
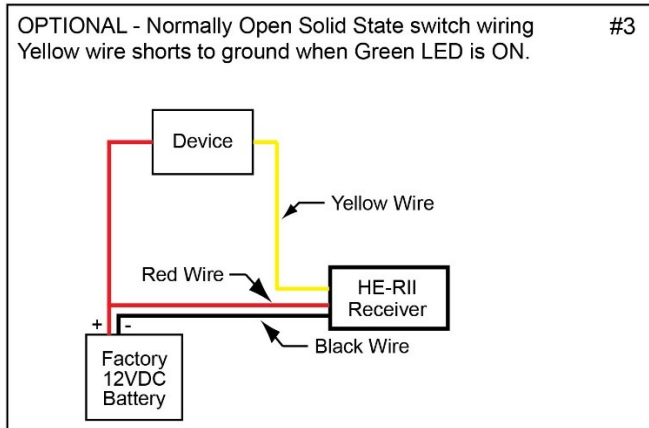

- a. Yellow wire [diagram #3] - When the *Receiver's* Green LED is on, the yellow wire is connected to ground.
- b. Orange wire [diagram #4] - When the *Receiver's* Red LED is on, the orange wire is connected to ground.

PROGRAMMING

- **NORMALLY-OPEN MODE. (Image #2)**

This step must be performed if connecting as normally open.

When the *Receiver* is powered on, the relay is in a closed state (normally-closed) by default. Some ignition systems like the MSD Pro Mag 12 need a normally-open relay operation. This method allows you to change the operation of the *Receiver* so that when the *Receiver* is powered on, the relay is in an open state and does not allow electricity to flow.

- 1) Turn *Receiver* off and then back on to determine its current state. Check the *Receiver* LEDs immediately after power up.
 - a. The yellow LED will illuminate and the Red LED will flash to indicate normally-closed mode.
 - b. The yellow LED will illuminate and the Green LED will flash to indicate normally-open mode.
- 2) Turn *Receiver* and *Transmitter* off.
- 3) Turn *Receiver* ON and make sure the green or red LED is on to show Run or Off mode. Proceed to steps #4 & #5 within 10 seconds.
- 4) Press and hold the RED button on the *Transmitter*.
- 5) Turn the *Transmitter* ON via the toggle switch.
- 6) Continue to hold the RED transmitter button for at least 15 seconds.
- 7) The *Receiver's* LEDs will blink to indicate mode change.
- 8) Release the red button on the *Transmitter*
- 9) Perform Step #1 in this section to confirm desired mode.

- STATUS CHECK MODIFICATION

Transmitter asks the *Receiver* if it is in Off or Run mode every 30 seconds. This can be disabled, if desired.

- 1) Turn *Receiver* and *Transmitter* off.
- 2) Press and hold the green button on the *Transmitter*.
- 3) Turn the *Transmitter* on via the toggle switch.
- 4) Continue to hold the green button for at least 15 seconds.
- 5) The *Transmitter's* LEDs will blink:
 - a. If the green LED blinks, the *Receiver* is in Status Check Every 30 Seconds mode.
 - b. If the red LED blinks, the *Receiver* will not check status every 30 seconds.

ADDITIONAL FEATURES

- The *Transmitter* queries the *Receiver* on power-up, during every button press, and every 30 seconds. 30-second check is optional; see Programming section.
- The *Transmitter* will automatically power off after 6 hours of inactivity to conserve the battery. Turn off and on again to reset.
- Press the Green button to check range status without shutting off the vehicle.

These instructions are subject to change without notice.

www.heliosure.com
Sales & Support: sales@heliosure.com
818-688-7550



North Hollywood, CA